

TECHNICAL SUBMITTAL

IndustrieWert GmbH
DATA SHEET
Lot No. 1 - 4

I. Technical Submittal: Chillers

II. Description of Technical Submittal:

Within this Technical Submittal, is the information required for the 4no. YMC2 York Chillers, to be located in the U2 Chiller Plant room. The chiller is custom built based upon the project requirements. Individual selections may have a combination of Motor, Compressor, Evaporator, and Condenser and Nozzle Arrangements to suit the specific project.

Detailed Lifting requirements and weights are confirmed on the attached Data sheets.

- Model: YMC2-S0900BAS
- Specified Net Capacity (kW) 900
- Heat Rejection Capacity (kW) 1116
- Input Power (Kw): 211.8 400V/50hz

Lead Time: 17-19 Weeks

To confirm Previous comments on Rev 01: Please refer to Technical Submittal FES Number: 075 for further information. We confirm this system comes with leak detection, Spring Av's, quick start function and harmonic filter (P15).

(P16) Confirm – The unit comes with electronic expansion valve, head pressure control, crank case heaters, flow switches, pre-wired control panel with all necessities.

(P18) Option was not instructed.

(P20) Testing option was not instructed. Point 18. Refer to Tech sub 75

III. Manufacturer: Johnson Controls

IV. Consultant Ref.: Water Cooled Chillers

V. Colour/Finish: Steel Powder Coated Green

VI. Details Attached to this Tech Sub: 20-03162-TI-002 YMC2 York Chillers by Johnson Controls Technical Data

Magnetic Bearing Centrifugal, Lubrication Free offering



The recognition for energy efficient chillers is more apparent now the ever before. YORK has more than 30 years' experience in the development of inverter driven large capacity water-cooled chillers. We proudly introduce the York

"YMC2" High efficiency, lubrication free, variable geometry compressor chiller.

Main Features & Key Benefits

1. Variable Speed Drive Technology
(Starting current will never exceed maximum running current)
2. 0.97 Power Factor
3. Low Sound
4. Low harmonic distortion VSD drive: Active Harmonic Filtering
5. High Efficiency at low condenser water temperatures (with part load EER's above 20) and the capability for low cooling capacity operation with high condenser water temperatures
6. Quick start function

Operating conditions – 900kW chillers

	Requested	Selected
Cooling Capacity (kW)	900	900
Power input	212	212
Chilled Water In/Out (°C)	12 / 6	12 / 6
Condensing Temp In/Out (°C)	36 / 43	36 / 43
Amps	320	320
Refrigerant type	R513A	R513A

Chiller selection(s): - Centrifugal Packaged Water-Cooled chillers

Centrifugal Chiller Accessories & Options (Included within the quoted price)

- ⚙️ Non Flammable, Low GWP, R513A refrigerant (electrical items do not need to be Atex rated or the plantroom automatically electrically isolated in the event of a refrigerant leak reaching 25% of the LFL for the refrigerant as required by EN-378-3).
- ⚙️ Variable speed and geometry compressors for increased operating range and the highest operating efficiency at part load operation. If there is a problem with the heat rejection system, the York chillers can operate from a little as 15% cooling capacity with the design entering condenser water temperature. This feature is also known as OptiSound as it reduces the sound levels as well as increasing the operating range.
- ⚙️ Integral factory fitted variable speed drive control panel – The chillers VSD is fully factory packaged and does not require the installer to provide additional pipework, valves or pumps within their pipework systems or to provide any power or control wiring between the chiller and the VSD. Please note that the VSD is a York design that is fully integrated within the chillers control architecture and is not a modified standard VSD. The York VSD is maintained and commissioned by our Service Engineers and we are not reliant on 3rd parties for maintenance, diagnostic investigation or parts.
- ⚙️ 0.97 Power Factor Correction via Active Harmonic Filtering.
- ⚙️ Two stainless steel electronic flow switches per chiller – factory fitted integral to the chiller to save you the cost of site fitting and wiring. The flow switches are also electronic (not the paddle type) have a far greater reliability, impose less of a pressure drop to the hydraulic circuit and have no moving parts for longer life expectancy. Please refer to the diagram below for the method of operation.

with an extract from the
 YORK product catalogue

YMC² Water-cooled magnetic centrifugal chiller

Cooling capacities from 800 kW to 3500 kW

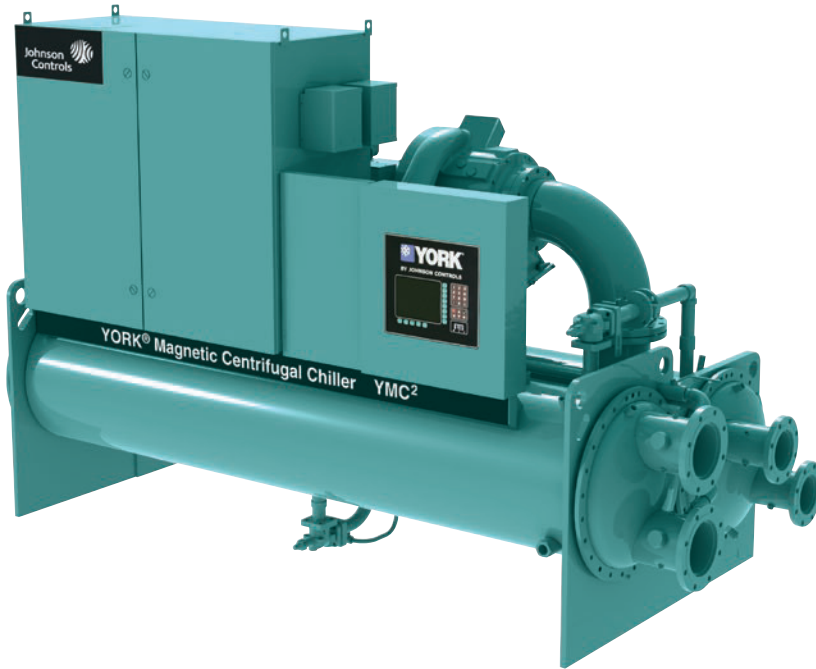

“Tailor and tune”
 customized units around
 job specific design.

Features

Enhanced efficiency

Achieved through application of active magnetic bearing technology with variable speed drive.

Enhanced sustainability

Achieved by leak free refrigerant design, lower refrigerant charge and falling film evaporator.

Low sound levels

Advanced technology results in sound levels as low as 75dBA.

Superior reliability

Use of active magnetic bearing technology removes friction and the need for oil resulting in a quieter and more reliable chiller.

Superior reliability

Between the centrifugal technologies, this series has the smallest dimensions, fitting where others simply cannot.

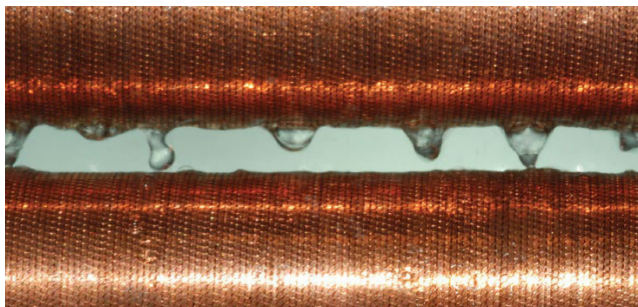

A falling-film evaporator is more efficient because refrigerant is sprayed over the tubes, offering improved heat transfer and reducing refrigerant charge by 30%.

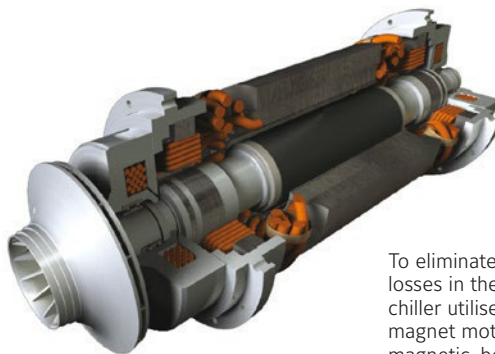

To eliminate mechanical-contact losses in the driveline, the YMC² chiller utilises a permanent-magnet motor and active magnetic-bearing technology.

Photo courtesy of the LITCM lab of the Ecole Polytechnique Fédérale de Lausanne, Switzerland

Water-cooled magnetic centrifugal chiller

YMC² S0800AA to S3500AB



YMC² are customized centrifugal units with job specific design. See below table as a reference, within Ecodesign capacity range.

Performances

YMC ²	S0800AA	S1000AA	S1200AB	S1400AA	S1600AB	S1800AB	S2000AB
Cooling capacity (kW)	800	1000	1200	1400	1600	1800	2000
EER	6.06	6.13	6.32	6.33	6.31	6.07	6
SEER	7.58	7.83	7.92	8.34	8.59	7.83	8.16
η _{s, c}	300	310	304	331	340	310	323
Sound pressure at 1 m (dBA)	77	77	76	76	77	79	80

Ratings in accordance to Ecodesign, fixed water flow and fixed outlet (FW/FO). For other Ecodesign calculations please contact your JCI Representative. The table above shows only a representative sample of performance points based on generic project operating conditions working with R513A refrigerant. For larger capacities up to 3500 kW or R134a information, contact JCI Representative. The above data is based on Johnson Controls' selection software YORKworks 21.00. Please refer to the latest version of the software for specific projects.

Technical data

YMC ²			S0800AA	S1000AA	S1200AB	S1400AA	S1600AB	S1800AB	S2000AB	
Dimensions	Length	mm	3048				4267			
	Width	mm	1880				2007			
	Height	mm	2410				2499		2573	
Shipping weight (kg)			5171		5810		6579		7809	
Refrigerant charge (kg)			278	280	423	454	445	612	656	

- All dimensions are approximate. Certified dimensions are available on request.
- Refrigerant charge quantity and shipping weights will vary based on tube count.
- Shipping weights are based on fully assembled and charged units.
- Refer to product drawings for detailed weight information.

Superior sound reduction

A-Weighted sound pressure level (dBA (re: 20μPa))
Measured in accordance with AHRI-575

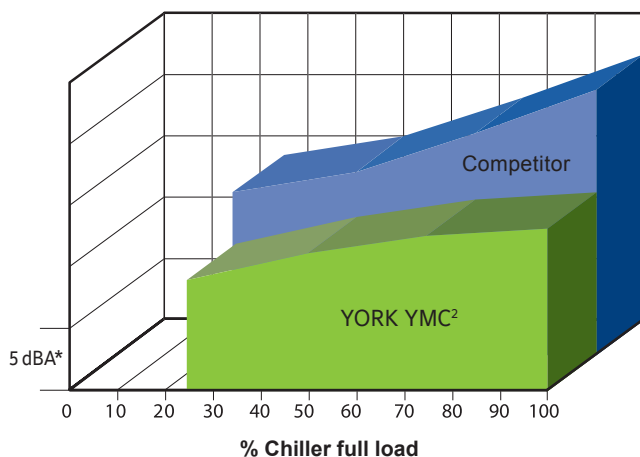

The YMC² chiller is so much quieter than competitive magnetic-bearing chillers, it sounds about half as loud.
*Note: each segment on the Y axis = 5 dBA.

OptiView control centre

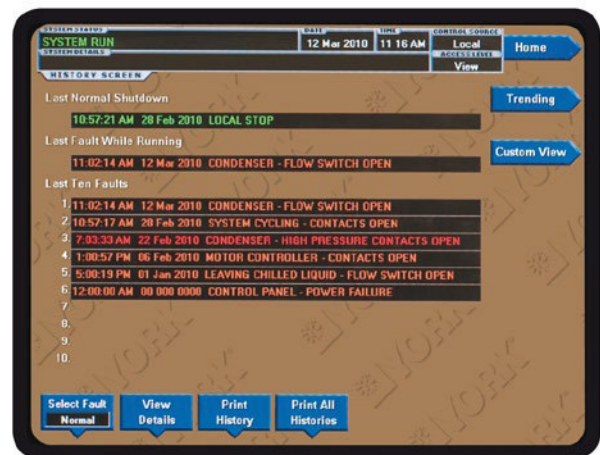

The OptiView control centre provides complete diagnostics to speed troubleshooting.



Manufacturer reserves the rights to change specifications without prior notice.

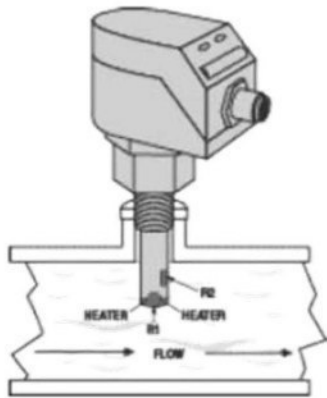

SI tip design



Thermography of flow monitor with no flow. The color graduations around the sensor tip show how the fluid is heated up by the heat source within the flow monitor.

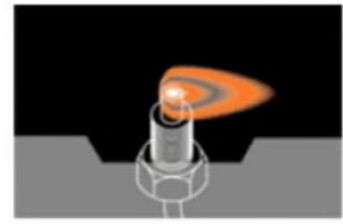

Thermography with fluid flowing. The heat generated by the flow monitor is conducted away from the sensor, essentially reducing the sensor temperature.

- + Spring AV mounts (4 sets) – supplied loose for site fitting. These provide greater vibrational isolation to that provided by neoprene or Tico type mountings. They also have the second benefit of reduced installation costs as the mounts can simply be adjusted to level the chiller without having to resort to shims of various thickness to level the chiller. The spring mountings generally offer 99.6% isolation at maximum speed.
- + Inverter drive per compressor resulting in starting currents less than full load amps – This reduces strain on the electrical supply / switchgear. It also allows a very short time between chiller starts if low cooling loads are witnessed. The chiller has a zero second anti-recycle timer for the first five starts.
- + Quickstart with UPS feature - The YMC2 chiller is fitted with an internal UPS system. The battery is sufficiently sized to provide power for the critical loads at worst-case conditions for the longest shutdown time possible during a loss of line power. The UPS can power the chiller controls for up to 5 minutes following a power failure.
- + Infinitely Variable Modulating compressor capacity control from 10% to 100% to accurately match the applied cooling load.
- + Electronic expansion device – For precise and economical control of the refrigerant flow and chilled water temperature to reduce operating costs.



- 10 Bar waterside pressure for Evaporator with ISO flanged connections.
- 10 Bar waterside pressure for Condenser with ISO flanged connections.
- Volt Free Contacts for remote on/off, general fault, run and pump start – There are a host of volt free connections available so the client has the option of hard wired interfaces or direct BMS communication flexibility.
- SC- EQ BMS communication interface for BacNet, Modbus or N2 – Allows simple connection to a BMS system using any one of the above protocols. It also has the capability to connect to our “Smart Connected Chillers” monitoring system as part of a maintenance programme. This system has been found to reduce maintenance costs and downtime for some clients.

Smart Connected Chiller Maintenance – The system is based on ‘chiller connectivity’ with cloud-based data collection / analytics, and automated monitoring / response capabilities. It is a secure system that uses York and Metasys technology to establish a link into the real-time operation of your connected chiller (or chillers).

Trend and operating data is stored on servers where technicians can access real-time operational trends via smartphone, tablet or pc. This allows them to analyse operating data and identify any abnormal conditions. This provides a pro-active rather than reactive approach to the maintenance of the chillers and any emerging operating conditions which could adversely affect the chiller operation or efficiency.

Additionally, alarms are monitored and any alarm information is forwarded to the local service division for investigation and action.

By utilising chiller dashboards and analytics tools, problems can sometimes be prevented before they happen... There is just a phone call that tells you there is preventative maintenance requirement that you should consider and a recommendation for when you should schedule a service call.

- ✚ Single Point Non – Fused Disconnect Switch / Circuit Breaker (CE) – Provides simple power connection and enhanced protection and simple reset compared to the typical fused type protection which would require fuse replacement following any fault.
- ✚ C.E, P.E.D and AHRI certification to comply with the current legislative requirements in respect to operating efficiency, safety standards and accuracy of stated performance. Although the operating conditions of this project are outside the rating envelope of the AHRI standard, our compliance with this standard gives the comfort that the equipment proposed will perform in accordance with our rating programme.
- ✚ Dual refrigerant relief valves – To allow compliance with F-Gas and insurance requirements for the inspection and replacement of the chiller relief valves without the need to remove the refrigerant charge.



- ✚ Chiller refrigerant isolation valves – Allows the refrigerant charge to be manually isolated within various parts of the chiller for simplified maintenance activities and as noted in BREEAM.
- ✚ Advanced pictorial screen Micro-Processor graphical control panel capable of fully displaying operating conditions, diagnostic, history, testing and system trending. The system is simple to operate, easy to understand and contains a number of password levels to minimise the chances of people accessing information and settings beyond their set allowance. Please see details of some sample screens shown below.
- ✚ Commissioning by York / JCI factory trained engineers. – We have one of the largest and skilled service teams within the Germany. The Service Division have access to the factory for support, software upgrades and genuine factory replacement parts.

YMC2 Chiller Technical Detail

T60sch5 – Schedule of Water Cooled Chillers

York information in blue text. ✓ = compliance with the schedule data.

CHILLER REFERENCE		WCH-U2-01	WCH-U2-02	WCH-U2-03	WCH-U2-04
System		Primary Chilled Water System			
Location		U2 – Heating / Cooling Plantroom			
Type		Vapour compression			
Limiting Dimensions l x w x h (mm)		3,700 x 1,800 x 2,050 each ✓			
Limiting Weight (Kg)		5,800 Kg each (operating) ✓ 5784kg			
Refrigerant		R513A ✓			
Evaporator type		Shell and tube ✓ Falling film for reduction in refrigerant quantity			
Fluid to be cooled (Chilled Water)		Water			
Heat Rejection Fluid (Condenser Water)		32% Ethylene Glycol ✓			
Compressor type		Centrifugal Compressor (Magnetic bearing) ✓			
DUTY					
Cooling capacity at design conditions (kW)		900 kW	900 kW	900 kW	900 kW ✓
Min No of passes		2 No.	2 No.	2 No.	2 No. ✓
Min No of control stages / machine		Fully modulating control from 15% to 100% of design load ✓			
Capacity control method		Variable speed drive (Inverter driven) ✓			
Electrical					
• Power input (kW)		212 kW	212 kW	212 kW	212 kW ✓
• Limiting full load current drawn (A)		320 A	320 A	320 A	320 A ✓
• Electrical supply- (phase /volts / Hz)		3 Ph / 400 V / 50 Hz	3 Ph / 400 V / 50 Hz	3 Ph / 400 V / 50 Hz	3 Ph / 400 V / 50 Hz ✓
Chilled Water					
• Flow rate maximum (l/s)		35.80 l/s	35.80 l/s	35.80 l/s	35.80 l/s ✓
• Maximum pressure drop (kPa)		35 kPa	35 kPa	35 kPa	35 kPa ✓
• Maximum working pressure (Bar)		8 Bar	8 Bar	8 Bar	8 Bar ✓
• Entering temperature (°C)		12 °C	12 °C	12 °C	12 °C ✓
• Leaving temperature (°C)		6 °C	6 °C	6 °C	6 °C ✓
Condenser Water					
• Flow rate (l/s)		41.40 l/s	41.40 l/s	41.40 l/s	41.40 l/s ✓
• Maximum pressure drop (kPa)		30 kPa	30 kPa	30 kPa	30 kPa ✓
• Maximum working pressure (Bar)		8 Bar	8 Bar	8 Bar	8 Bar ✓
• Entering temperature (°C)		36 °C	36 °C	36 °C	36 °C ✓
• Leaving temperature (°C)		43 °C	43 °C	43 °C	43 °C ✓
Limiting Fouling factors:					
• Evaporator		0.020m ² °C/kW			
• Condenser		0.044m ² °C/kW ✓			
ENERGY EFFICIENCY / SEASONAL ENERGY EFFICIENCY					
EER	Min at 100% cooling output	4.250	4.250	4.250	4.250 ✓
	Min at 75% full cooling output	~6.200	~6.200	~6.200	~6.200
	Min at 50% full cooling output	9.745	9.745	9.745	9.745
	Min at 25% full cooling output	~8.600	~8.600	~8.600	~8.600
ESEER	Minimum overall seasonal energy efficiency ratio for chiller at std Eurovent conditions / weighting factors	-8.150	-8.150	-8.150	-8.150 9.31 @ ESEER ✓
Limiting sound - A-Weighted SPL (dB A)		78	78	78	78 ✓
ANCILARIES / ACCESSORIES					
Accessories		<ul style="list-style-type: none"> Leak detection system – see notes for details and W54sch. ✓ Include spring AV's for levelling of each machine and vibration isolation. ✓ Quick start function ✓ Harmonic filter ✓ 			

Selected water cooled chiller manufacturer, hybrid cooler manufacturer and water treatment specialist shall work together to provide a full working solution in compliance with the specification and the scheduled data.

Notes:

1.	Unit selection based on 'York YMC2' magnetic centrifugal chiller type or equal and approved.
2.	Units to be installed strictly in accordance with manufacturer's instructions.
3.	Provide electronic expansion valve, head pressure control, crank-case heaters (not reqd) , flow switches (factory fitted), pre-wired control panel with all necessary controls and safety devices, terminal connections and auxiliary relays. All controls to be fully electronic. ✓
4.	Controls to be capable of external load shedding via BMS. ✓
5.	Provide modem for full BMS interrogation of all chiller set points, temperatures, pressures, alarms etc and adjustment of all main set points and , configure the modem to download plant logs to the BMS once a day.
6.	Provide a fixed automatic refrigerant leak detection system as part of the package to cover the water cooled chillers and the 2 chiller enclosures as indicated on the plantroom U2 drawings – also refer to W54sch. <ul style="list-style-type: none"> System is to comply with the requirements of ASHRAE Standard 15 and BS EN 378. The leak detection shall interface with the BMS and raise a critical alarm. An indication panel / alarm shall be provided on both sides of the main access to each enclosure. The leak detection system provided in each of the enclosures shall have the ability to connect to the ventilation system serving the enclosure to signal the system to 'emergency ventilation' mode. Refer to clause T60 300.077 for further details. Refer to U2 drawings for chiller location and the two enclosures. Comply with the above items Emergency switch to be provided both inside and outside of main door to switch the chillers off. By others
7.	Provide integral controls to start compressors in stepped manner (both in morning start up and restart after power failure) to prevent surges on mains supply. ✓
8.	Units to be provided with integral power factor correction to achieve a minimum of 0.95 and shall be provided by the chiller manufacturer. ✓
9.	Provide separate door interlocking mechanism for each mains compartment. Only a single power supply & isolator
10.	The chiller shall not exhibit any tonal character. This is defined as "no 1/3 octave band sound pressure level measured at 1m shall differ from its two adjacent 1/3 octaves by more than 5dB". This shall be demonstrated prior to installation on site. ✓
11.	The sound pressure level specification is the maximum noise level around all sides of the chiller, not the average level. Sound is based upon the average as AHRI and EN standards
12.	Provide complete automatic refrigerant pump down facilities to a heat exchanger (or dedicated storage tanks) with isolation valves equipment to recover evacuated refrigerant for reuse. It is not possible for a centrifugal compressor to pump down. However, isolation valves are provides for refrigerant isolation. A separate refrigerant recovery system is available.
13.	All chillers shall have dual safety valves complete with 3-way cock so that each valve can be removed without pumping-down or non-operation of the chiller. ✓
14.	Undertake works testing as detailed in the specification (T60). ✓ Provided as an option.
15.	Comply with the requirements of reference sections Y72 & Y92 for motors and starters and W60 for controls. Motors are moving magnet type and high efficiency.
16.	Units to be commissioned by manufacturer allowing for final leak testing, charging, the initial startup and conduct concurrent operator instruction. ✓
17.	Provide volt free contacts for each chiller to signal the following alarms and any others listed on the Controls drawings: Common fault; low chilled water flow; high pressure fault. ✓
18.	For multi chiller installations, provide a chiller sequence controller to allow sequence control of xx chillers. In addition to each chiller's outlet temperature control and protection sensor, provide common chiller inlet and outlet temperature sensors and incorporate capacity control sensor selection at the sequence control panel. Ensure the chiller sequence controller allows control in all possible sequence permutations. Ensure the control system optimises chiller and compressor run and load sequence by varying control parameters to maintain common fluid outlet temperature. Incorporate the facility to carry out automatic compressor and chiller lead/lag selection to balance compressor and chiller run hours. Non-Compliant. We believe the whole system needs to be controlled to allow higher efficiencies to be achieved.
19.	Contactors / Starters / for chilled primary water pumps shall be hard wire interlocked with chiller controls to prevent operation of the chiller if the pump is not operating. Noted.
20.	Chillers to comply with EU Regulation 2016/2281 with regard to ecodesign requirements, including seasonal space cooling, energy efficiency (SSCEE / SSHE) and product information. Minimum EER at part load, for calculation of SEER (Seasonal Energy Efficiency Ratio) to EU 2016/2281 (Ecodesign requirements) and BS EN 14825. Evaporator temperatures in accordance with BS EN 14825:2016 (table 5 – water cooled). ✓



Project:
Unit Tag:
Engineer:
Customer:

Rating Program: XEngine 1.0.7479
Software Version: YW 20.02a
Date: 07/09/2020 16:24:35

SALES REPORT

Unit Specifications			
Model	YMC2-S0900BAS	Refrigerant	R513A
Specified Net Capacity (kW)	900.0	Refrigerant Charge (kg)	302
Rated Net Capacity (kW)	900.0	Variable Orifice	V2
Heat Rejection Capacity (kW)	1116		
Full Load (COP.R)	4.249	Isolation Valve	Y
IPLV.IP (COP.R)	9.487		
NPLV.IP (COP.R)	8.177	OptiSound Control	Y
Input Power (kW)	211.8	Voltage / Hz	400 / 50.0
Starter Type	HYP0490XHC***-50A	FLA (Amps)	320
Compressor	M1B-197FAB	A-Weighted SPL (dBA)	78
Evaporator	EA2510-371-CS*-2***	Min Circuit Ampacity	400
Condenser	CA2510-260-CS*-2***	Max Circuit Breaker Amps	700

	Evaporator	Condenser
Fluid	Water*	Ethylene Glycol*
% by weight		32.0
Tube MTI No.	371	260 / 260
Passes	2*	2*
Fouling Factor (m ² ·°C/kW)	0.01761	0.04403
Entering Fluid Temp (°C)	12.00	36.00
Leaving Fluid Temp (°C)	6.00	43.00
Fluid Flow (L/s)	35.75	41.37
Fluid Pressure Drop (kPa H2O)	31.6	28.5

(*) Designates User Specified Input

Certified in accordance with the AHRI Water-Cooled Water-chilling and Heat Pump Water-Heating Packages Certification Program, which is based on AHRI Standard 550/590 (I-P) and AHRI Standard 551/591 (SI). Certified units may be found in the AHRI Directory at www.ahridirectory.org.

Unit contains freeze protection fluids in the condenser or in the evaporator with a leaving chilled fluid temperature above 32°F [0°C] is certified when rated per the Standard with water.

- Compliant with ASHRAE 90.1-2004.
- Compliant with ASHRAE 90.1-2007.
- Compliant with ASHRAE 90.1-2010.
- Compliant with ASHRAE 90.1-2013.
- Compliant with ASHRAE 90.1-2016.

Compliant with the requirements of the LEED Energy and Atmosphere Enhanced Refrigerant Management Credit (EAc4).

Materials and construction per mechanical specifications - Form 160.78-EG1.
Auxiliary components included in total kW - Chiller controls.





Project:
Unit Tag:
Engineer:
Customer:

Rating Program: XEngine 1.0.7479
Software Version: YW 20.02a
Date: 07/09/2020 16:24:35

Partload Data (Minimum Condenser Water Temperature)									
CEFT (°C)	% LOAD								
	100%	90%	80%	70%	60%	50%	40%	30%	20%
36.00°	4.249	4.296	4.317	4.302	4.234	4.093	3.864	3.525	-
33.00°	4.752	4.837	4.882	4.860	4.785	4.634	4.389	4.019	-
30.00°	5.341	5.426	5.465	5.467	5.402	5.241	4.973	4.540	3.946
27.00°	5.986	6.123	6.214	6.216	6.144	5.985	5.700	5.259	4.533
24.00°	6.788	6.966	7.102	7.190	7.210	7.091	6.793	6.225	5.334
21.00°	7.713	7.979	8.234	8.419	8.506	8.455	8.184	7.601	6.350
18.00°	8.796	9.216	9.616	9.975	10.20	10.20	9.966	9.456	8.247
15.00°	10.11	10.71	11.31	11.96	12.51	12.63	12.46	11.95	10.63
12.00°	11.74	12.60	13.46	14.43	15.33	15.92	16.12	15.81	14.39
9.00°	13.96	15.23	16.49	18.09	19.69	21.27	22.43	22.66	21.50
6.00°	15.94	17.50	19.51	21.79	24.67	27.85	30.02	30.43	27.29
5.00°	16.95	18.81	21.23	24.11	27.62	30.59	33.11	33.71	29.70

*Values are in COP.R

Rated point is 60% or higher efficiency compared to design operation point.
Rated point is 70% or higher efficiency compared to design operation point.
Rated point is 80% or higher efficiency compared to design operation point.

Certified in accordance with the AHRI Water-Cooled Water-Chilling and Heat Pump Water-Heating Packages Certification Program, which is based on AHRI Standard 550/590 (I-P) and AHRI Standard 551/591 (SI). Certified units may be found in the AHRI Directory at www.ahridirectory.org.

Unit contains freeze protection fluids in the condenser or in the evaporator with a leaving chilled fluid temperature above 32°F [0°C] is certified when rated per the Standard with water.
Compliant with ASHRAE 90.1-2004.
Compliant with ASHRAE 90.1-2007.
Compliant with ASHRAE 90.1-2010.
Compliant with ASHRAE 90.1-2013.
Compliant with ASHRAE 90.1-2016.

Compliant with the requirements of the LEED Energy and Atmosphere Enhanced Refrigerant Management Credit (EAc4).

Materials and construction per mechanical specifications - Form 160.78-EG1.



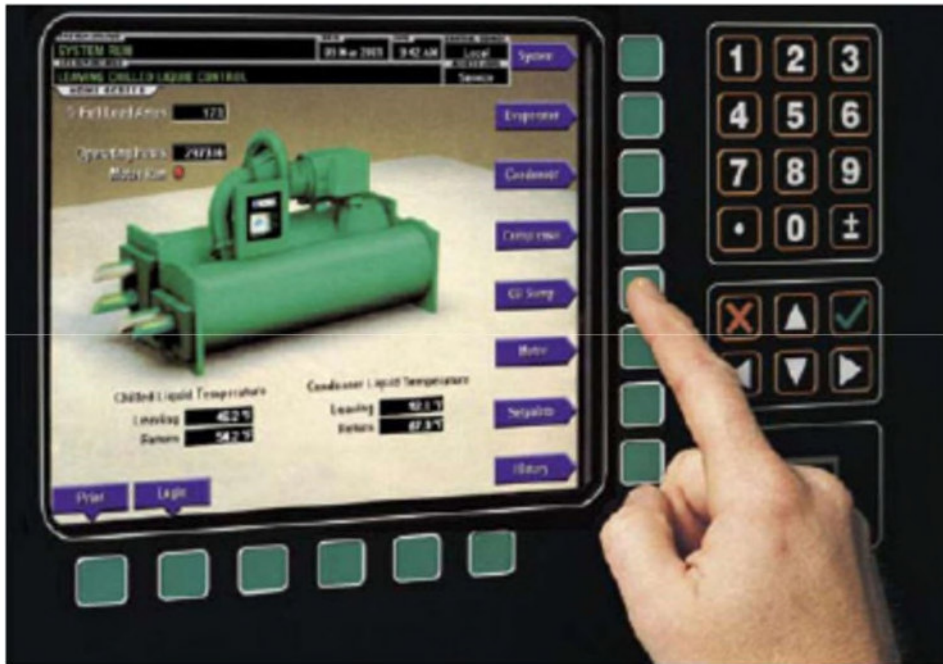

[Home Screen](#)

This is the default screen from which all other screens are navigated by a single press of a button. There are a host of detail screens for each item and system of the chiller. Three levels of security prevent accidental changes to system and operating data by unauthorised personnel.

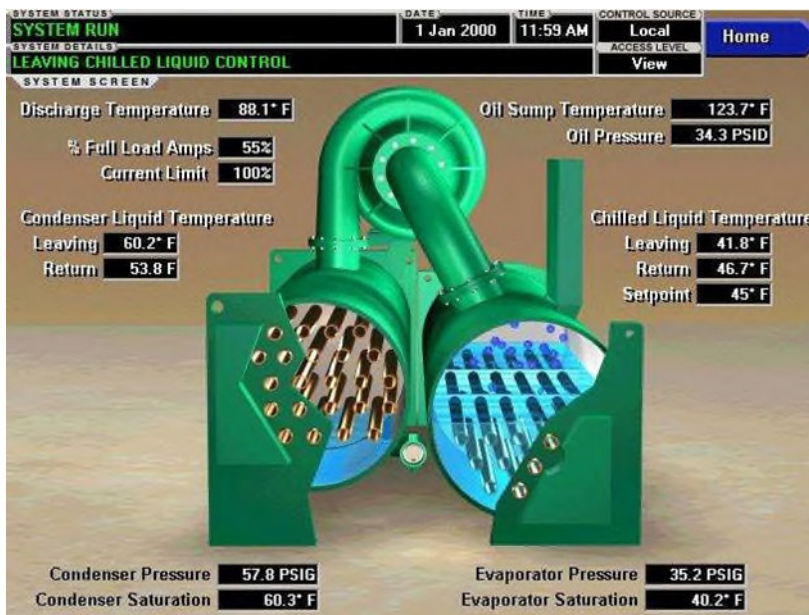

[System Screen](#)

This gives an overview of the refrigeration system in metric or imperial units. Separate screens are available for the evaporator, condenser compressor and VSD drive.

[Frictionless Magnetic Bearing Screen](#)

Using proven Magnetic Driveline Technology that has been incorporated in YORK chiller designs for more than 15 years, the majority of chiller components on the YMC2 have been time tested in the tens of thousands of YK chillers operating globally. The YORK YMC2 chillers employ the most advanced drive available - an active magnetic-bearing drive - to levitate the driveshaft in mid-air. The result is frictionless operation and fewer moving parts

This magnetic drive system has been used in our military grade chillers since 1999 and still provides critical cooling for applications ranging from submarines to the operations centre for the Kennedy Space Centre.

- Multiple bearing position sensors ensure proper operational alignments
- Corrects itself 1500 times per second

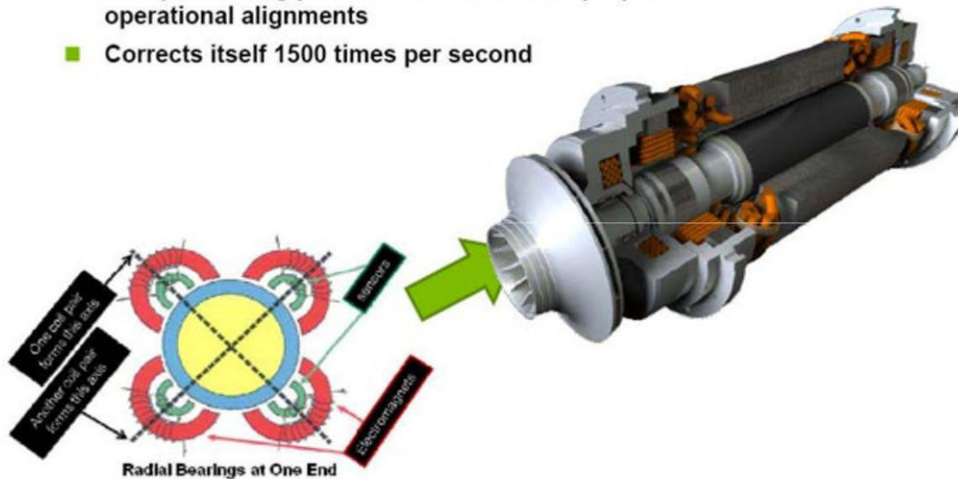

SYSTEM STATUS		DATE	TIME	CONTROL SOURCE	
SYSTEM READY TO START		18 Jun 2011	9:54 AM	Local	Service
SYSTEM DETAILS					
MAGNETIC BEARING CONTROLLER (MBC) SCREEN					
Motor Speed	X Hz	Opposite Impeller End Bearing		Compressor	
DC Bus Voltage	0 V	W2	X.XXX A	V2	X.XXX A
Impeller End Bearing		Z2	X.XXX A	MBC Details	
V13 Position	X μm	V4	X.XXX A	MBC Event Log	
W13 Position	X μm	W4	X.XXX A		
W1	X.XXX A	V1	X.XXX A	MBC Status	
Z1	X.XXX A	V24 Position	X μm	Delevitate Command	
V3	X.XXX A	W24 Position	X μm	<input checked="" type="radio"/> Delevitated Mode <input checked="" type="radio"/> Levitated Mode <input checked="" type="radio"/> Rotation Mode <input checked="" type="radio"/> MBC Shutdown	
Z12 Position	X μm	Rotor Elongation	X μm	MBC Outputs	
MBC Control Mode		Motor Housing Temperature	91.3 °F	<input checked="" type="radio"/> Rotation Allowed <input checked="" type="radio"/> MBC Fault	
Manual		Landing Counter	X		
Delevitate					
Auto					

The bearing control screen is accessible via the home screen giving the operator /engineer access to the temperature, multiple axis proximity and status of the magnetic bearings operation and operating log.



Johnson Controls
No1 Russel Square,
Hornsby Way,
Basildon.
SS15 6TA.

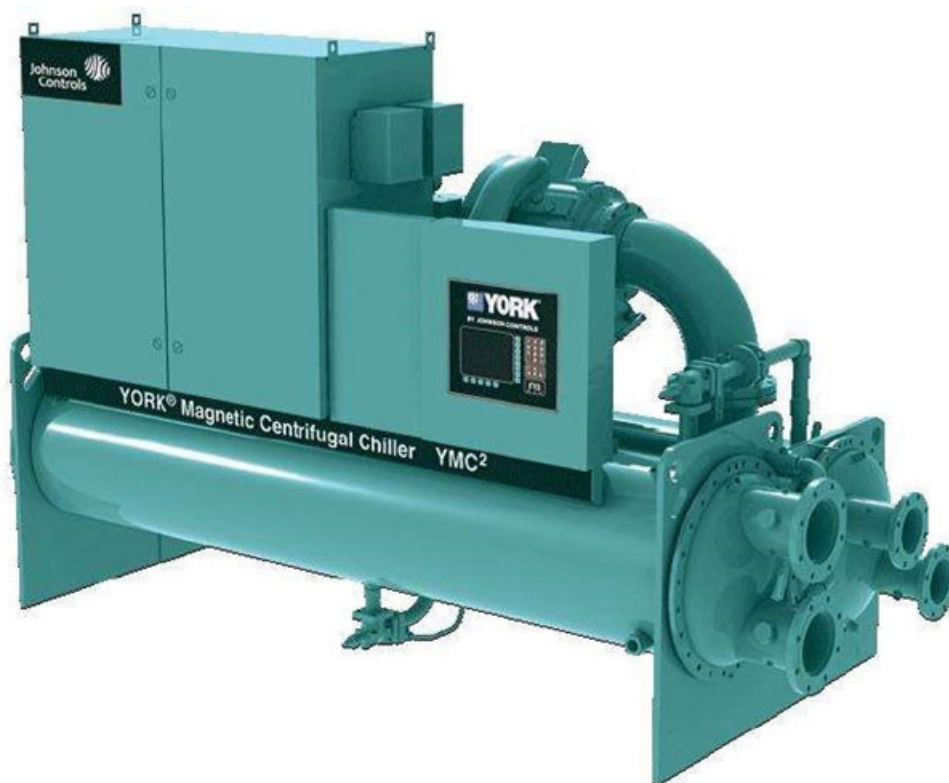

Document : Delivery Format – Form 7 Option
Supplier: Johnson Controls – York Chiller Plant
Prepared By: CTJ
Chiller Ref: WCH-U2-01 to WCH-U2-04

Rev: 01

Item 1: Shipment Forms Summary

Each chiller can be broken down into several form shipment configurations for ease of transportation and installation. For all broken down shipment options, the unit is first factory assembled, refrigerant piped, wired, leak tested and final tested. The chiller is then disassembled according to the shipment option selected.

A protective covering is furnished on the OptiView™ and VSD panels. Water nozzles are capped with fitted plastic enclosures. Then the entire unit is protected with industrial-grade, reinforced shrink-wrap covering.

Form 1 – Unit is shipped as one assembly with refrigerant charge inside the unit.

Form 2 – Unit is shipped as one assembly with refrigerant charge shipped separately.

Form 3 – Driveline separate from shells. Shipped as three major subassemblies with refrigerant charge shipped separately. This form is best used when height is a limiting dimension to enter the installation site.

Driveline (motor/compressor assembly)

Evaporator/Condenser shell assembly – not skidded Variable
Speed Drive

Form 7 – Driveline separate from split shells. Shipped as four major subassemblies, with refrigerant charge shipped separately. This form is best used when the chiller must fit through a tight space, limited by multiple dimensions.

Driveline (motor/compressor
assembly) Evaporator – not skidded
Condenser – not skidded Variable
Speed Drive

Forms 1 and 2 are largely self-explanatory. This document provides some additional information in relation to the Form 7 shipment option.

It is sometimes more economical to enlarge the access openings to accommodate the factory assembled unit. However, where this is not practical or possible the chillers can be shipped in component assemblies.

Chillers that are shipped dismantled MUST be field-assembled by or under the supervision of a Johnson Controls representative. The normally followed practice would be that the York Johnson Controls engineer(s) would work in cooperation with the plant movement specialist to complete the assembly of the chiller(s). The plant movement specialist would transport and lift the components into position with the final assembly, gasket, torque and sealing being provided by York Johnson Controls engineers.

Item 2: Chiller System Component Information

Figure 1 identifies the major components of the YMC2 Chiller. The chiller is custom built based upon the project requirements. Individual selections may have a combination of Motor, Compressor, Evaporator, and Condenser and Nozzle Arrangements to suit the specific project.

Each chiller will have the fundamental chiller components but optional components and features may be added or removed.

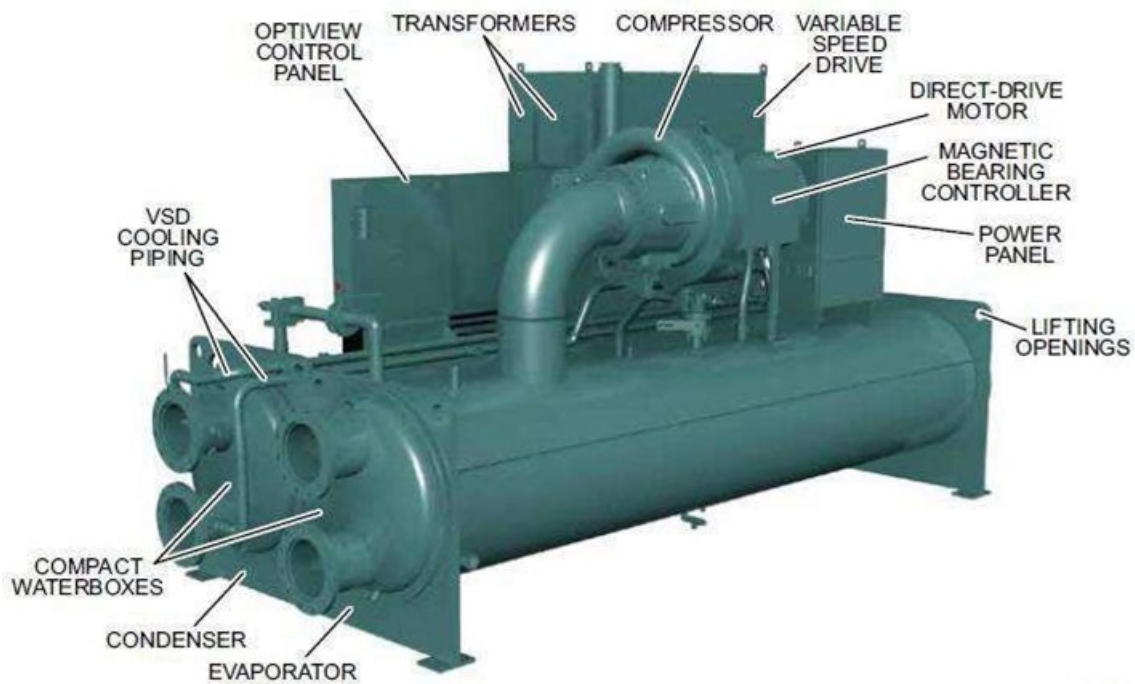

Item 3: Form 7 Shipment

The chiller is shipped in six separate assemblies:

1. The driveline (compressor/motor assembly).
2. The evaporator.
3. The condenser.
4. The Variable Speed Drive (VSD).
5. The OptiView™ Control Center assembly.
6. The Power Panel assembly.
7. Miscellaneous shipped loose items.

Note:

1. One lifting chain is required for each lifting point and each chain having a working load limit 40% of condenser and evaporator weight or heat exchanger being lifted.
2. The lifting chains or slings should respect the angles shown on the drawings.

1. Driveline

Driveline weight	1,221kg
Compressor weight	845kg
Driveline Dimensions (LxWxH)	1,200 x 1,055 x 855mm

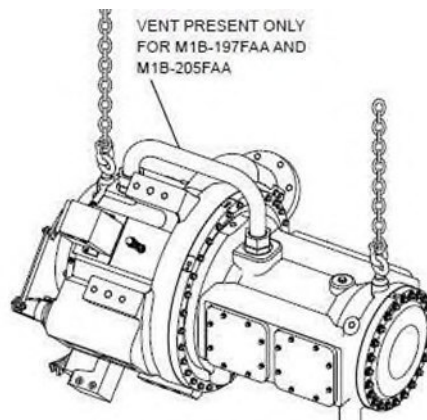

2. Evaporator

- Shell weight 1,569kg
- Shell Dimensions 3,669 x 788 x 1,054mm

3. Condenser

- Shell weight 1,641kg
- Shell Dimensions 3,669 x 1,575 x 1,135mm

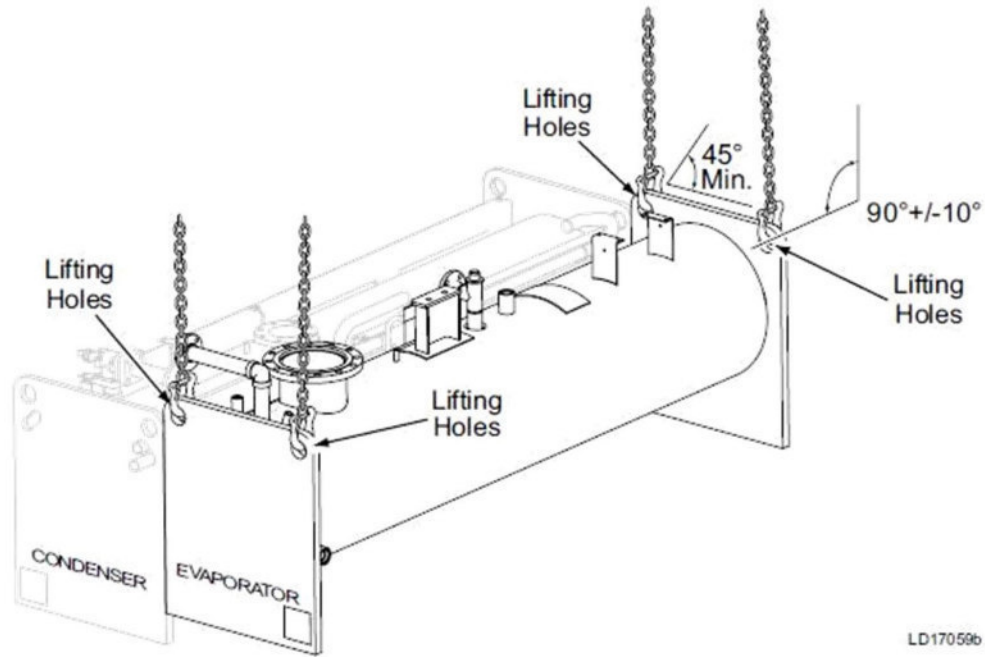

4. VSD Panel Assembly

- VSD weight 879 kg
- VSD Dimensions 1,353 x 670 x 1017mm

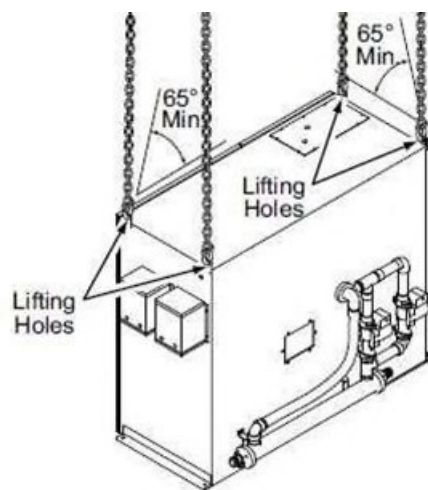

5. Power Panel Assembly

Power Panel weight	135 kg
Power Panel Dimensions	419 x 310 x 560mm

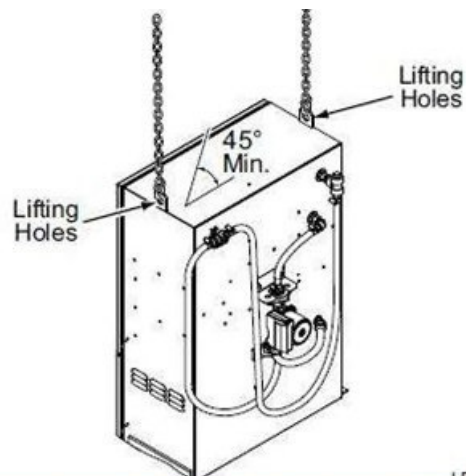

6. Miscellaneous Items

OptiView Panel weight	34 kg
OptiView Panel Dimensions	689 x 160 x 765mm

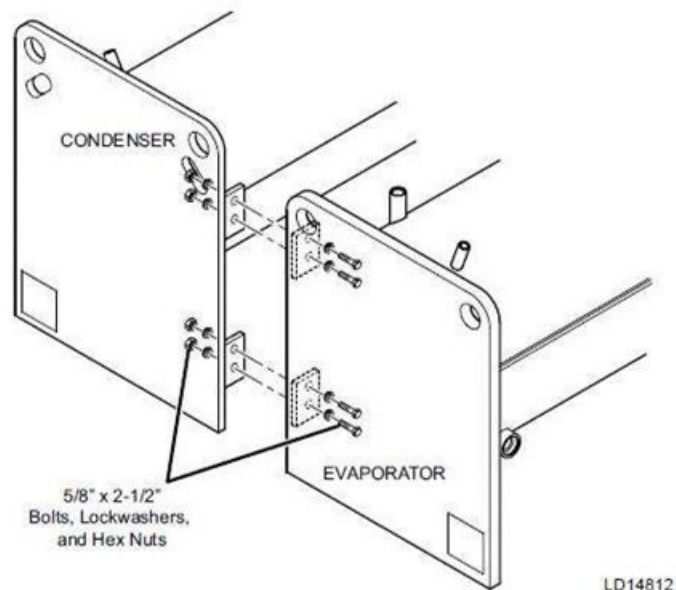

Assembly of heat exchangers – Form 7

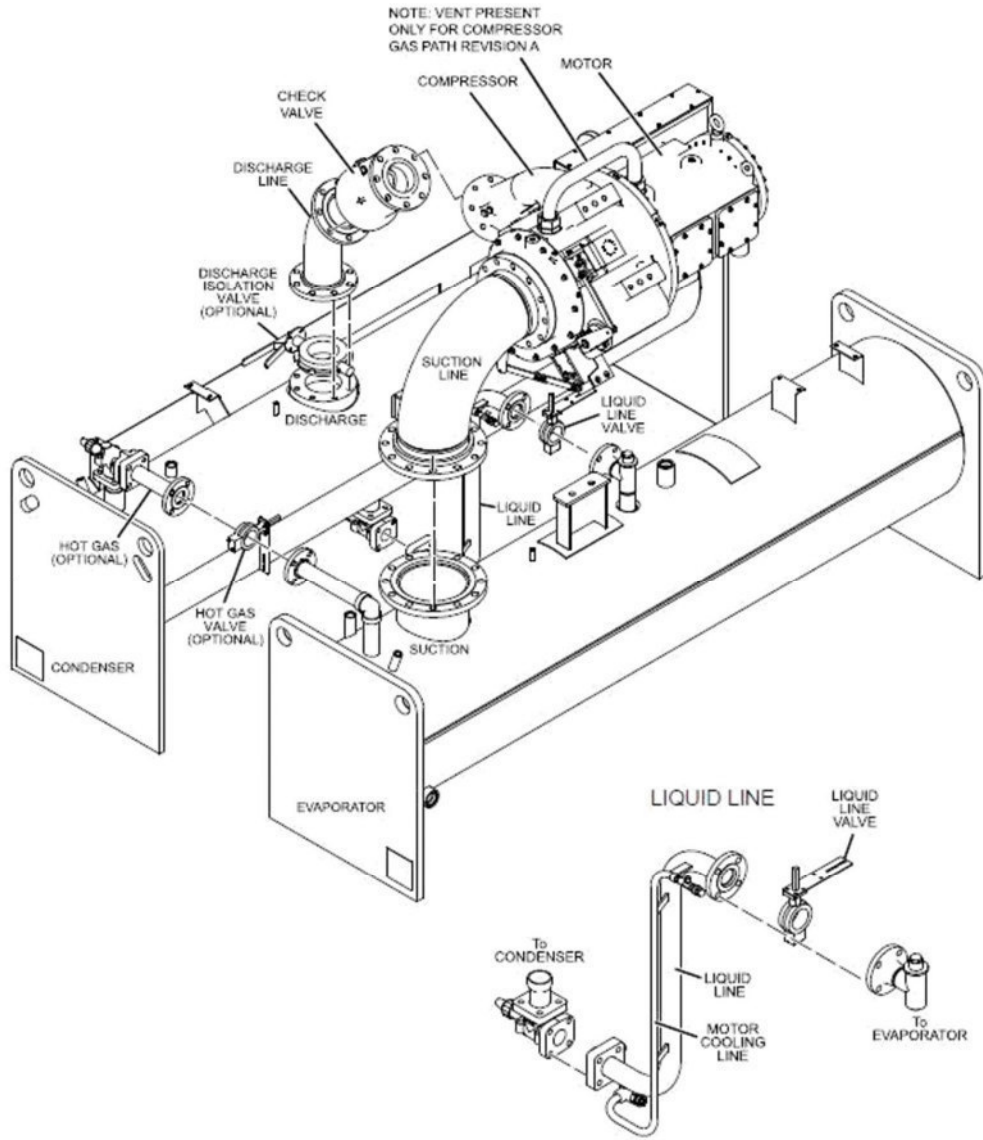

Standard Wärmepumpen



YVAG
Luft-Wasser WP
Scroll Verdichter / R410A
Warmwasser **bis zu 52°C**
Heizleist.: 10.9 bis 18.4 kW
Min. Wasseraustrittstemp. bis -10°C. Zertifiziert als hermetisch dichtes Gerät



YMPA
Luft-Wasser WP
Ausgezeichnet als Wärmepumpe des Jahres (ACR Awards)
Scroll / R410A & R454B
Warmwasser **bis zu 55°C**
Heizleist.: 50 bis 254 kW



YLPB
Luft-Wasser WP
Scroll Verdichter / R410A
Warmwasser **bis zu 55°C**
Heizleist.: 344 bis 653 kW
Option Wärmerückgewinnung verfügbar



YHA
Luft-Wasser WP
4-Rohr System
Scroll Verdichter / R410A
Warmwasser **bis zu 60°C**
Heizleist.: 22 bis 464 kW
Heizbetrieb bei Umgebungstemp. bis -20°C



YLZ
Luft-Wasser WP E.V.I
4-Rohr System
Scroll E.V.I / R410A
Duct ESP-Ventilatoren (Option)
Warmwasser **bis zu 65°C**
Heizleist.: 25 bis 210 kW
Heizbetrieb bei Umgebungstemp. bis -20°C



YMWA
Wasser-Wasser-WP
Scroll Verdichter / R410A
Warmwasser **bis zu 55°C**
Heizleist.: 24 bis 212 kW



YWH
Wasser-Wasser-WP
Scroll Verdichter / R134a
Warmwasser **bis zu 78°C**
Heizleist.: 38 bis 273 kW



YCSE
Wasser-Wasser-WP
Schrauben-Verdichter / R134a
Warmwasser **bis zu 60°C**
Heizleist.: 170 bis 300 kW



YCWL
Wasser-Wasser-WP
Scroll Verdichter / R410A
Warmwasser **bis zu 50°C**
Heizleist.: 200 bis 700 kW



YLCS
Wasser-Wasser-WP
Zweikreis Schraube / R134a
Warmwasser **bis zu 65°C**
Heizleist.: 440 bis 990 kW



YVWA
Wasser-Wasser-WP
VSD Schrauben-Verdichter / R513A
Warmwasser **bis zu 63°C**
Heizleistung: 600 bis 1000 kW



YVWH
Wasser-Wasser-WP
VSD Schrauben-Verdichter / R1234ze
Warmwasser **50°C**
Heizleistung: 315 bis 1250 kW



YMC²
Wasser-Wasser-WP
magnetgelagerter Turboverdichter und VSD-Antrieb / R134a & R513A
Warmwasser **50°C**
Heizleistung: 900 bis 4000 kW



YK
Wasser-Wasser-WP
Turbo Verdichter / R134a & R513A
Warmwasser **50°C**
Heizleistung: 1200 bis 13000 kW



HeatPAC recip
Ammoniak-Wärmepumpe
Kolbenverdichter mit VSD / R717
Warmwasser **bis zu 70°C**
Heizleistung: 300 bis 2000 kW
Warmwasser **bis zu 90°C (HPX)**
Heizleistung bis zu 1500 kW



DualPAC zweistufige
Ammoniak-Wärmepumpe
Kolbenverdichter mit VSD / R717
Warmwasser **bis zu 70°C**
Heizleistung: 400 bis 3000 kW
Warmwasser **bis zu 90°C (HPX)**
Heizleistung bis zu 1850 kW



YHAP
Absorptionswärmepumpe
Dampf, Gas oder Heißwasser-Antrieb / R718
Warmwasser **bis zu 95°C**
Heizleistung: 900 bis 40000 kW

Unsere Wärmepumpen werden staatlich gefördert. Kontaktieren Sie Ihren JCI-Vertreter für mehr Informationen.

Leitfaden für die Aufstellung von Flüssigkeitskühlern in Anlehnung an die DIN EN-378; (jeweils zum gültigen Stand 01/2021)

Kategorien von Zugangsbereichen gemäß EN 378-1:2016+A1:2020, 5.1

Die Zugangsbereiche gliedern sich in drei Klassen mit jeweils unterschiedlichen sicherheitstechnischen Anforderungen:

Klasse a: Allgemeiner Zugangsbereich. Räume, Gebäudeteile oder Gebäude, in denen

- Personen schlafen dürfen
- Personen in ihrer Bewegungsfreiheit eingeschränkt sind
- sich eine unkontrollierte Anzahl an Personen aufhält, die nicht mit den Sicherheitsvorkehrungen vertraut sind.

Zur Klasse a gehören beispielsweise Krankenhäuser, Gerichtsgebäude, Theater, Supermärkte, Bahnhöfe, Hotels und Wohnungen.

Klasse b: Überwachter Zugangsbereich; Räume, Gebäudeteile oder Gebäude, in denen

- sich nur eine bestimmte Anzahl an Personen aufhalten dürfen, von denen einige mit den Sicherheitsvorkehrungen der Einrichtung vertraut sein müssen.

Zur Klasse b gehören beispielsweise Laboratorien, Bürogebäude sowie Räume für Fabrikationszwecke.

Klasse c: Zugangsbereiche, zu denen nur befugte Personen Zutritt haben

- Räume, zu denen nur befugtes und mit den Sicherheitsvorkehrungen vertrautes Personal Zutritt hat.
- Räume in denen Materialien oder Güter hergestellt, verarbeitet oder gelagert werden.

Zur Klasse c gehören beispielsweise Produktionseinrichtungen für Chemikalien und Nahrungsmittel, Raffinerien sowie nicht öffentliche Bereiche bei Supermärkten.

Kältetechnische Komponenten für die Aufstellung im Freien gemäß EN 378-3:2016+A1:2020, 4.2

Kälteanlagen, die im Freien aufgestellt sind, sind so anzuordnen, dass kein Kältemittel durch Leckagen in das Gebäude gelangen oder auf andere Weise Personen oder Eigentum gefährden kann. Sind Kälteanlagen auf einem Gebäudedach aufgestellt, darf das Kältemittel bei einer Leckage nicht in Belüftungsöffnungen, Türöffnungen, Bodenklappen oder ähnliche Öffnungen eindringen.

Eine Schutzabdeckung für im Freien aufgestellte kältetechnische Komponenten muss mit einer natürlichen oder Zwangsbelüftung versehen sein.

Besonderheiten bei brennbaren Kältemitteln:

Wenn sich freigesetztes Kältemittel ansammeln kann, z.B. unter Erdgleiche, sind Belüftungen und ggf. Gasnachweissysteme erforderlich. Bei brennbaren Kältemitteln wie z.B. Propan (A3-Kältemittel) sind Schutzmaßnahmen gegen Brand- und Explosionsgefahren gem. DIN EN 378-2; 2017 Pkt. 6.2.14 zu ergreifen. Gegebenenfalls ist eine Bewertung der Zündgefahr und eine Einteilung für Zone 2 gem. DIN EN 60079-10-1:2016-10 vom Betreiber vorzunehmen.

Die Temperatur der Oberflächen von Komponenten, die z.B. bei einer Propan-Leckage dem Kältemittel ausgesetzt sind, darf die Selbstentzündungstemperatur (Propan: 470 °C) minus 100 K (also 470 °C - 100 °C = 370 °C) oder 80 % der Selbstentzündungstemperatur, je nach dem welcher Wert höher ist, nicht überschreiten (DIN EN 378-2; 2018; Pkt. 6.2.14 und EN 378-3:2016+A1:2020; Pkt. 5.14.4).

Darüber hinaus müssen die Anforderungen des Wasserhaushaltsgesetzes (WHG) und der Verordnung über Anlagen zum Umgang mit wassergefährdenden Stoffen (AwSV) beachtet werden.

Einhaltung des WHG und der AwSV

Im Rahmen der Gefährdungsbeurteilung zu bestimmten Füllmengen kann man dem Besorgnisgrundsatz (WHG) im Freien zum Beispiel durch die Installation von Füllstandüberwachung, Auffangwannen für Kältemittel, Öl bzw. Glykol und Detektionseinrichtungen folgen. Bei wassergefährdenden Stoffen wie z.B. mehr als 220 l Glykol oder Öl bzw. mehr als 200 kg Kältemittel gelten (bundeseinheitlich) spezielle Vorgaben in der AwSV.

Maschinenraum / separater Kältemaschinenraum gemäß EN 378-1:2016+A1:2020, 3.2.1; 3.2.2.

Maschinenraum:

Umschlossener Raum oder Bereich mit mechanischer Lüftung, der gegenüber öffentlichen Bereichen abgedichtet und der Öffentlichkeit nicht zugänglich sowie dafür vorgesehen ist, die Bauteile der Kälteanlage zu enthalten.

Ein Maschinenraum kann weitere Anlagen enthalten, vorausgesetzt seine Auslegung und die Anforderungen an deren Einbau sind mit den Anforderungen an die Sicherheit der Kälteanlage kompatibel.

Separater Kältemaschinenraum:

Maschinenraum, der nur zur Aufstellung von Teilen der Kälteanlage vorgesehen ist. Er ist nur für sachkundiges Personal zwecks Inspektion, Instandhaltung und Instandsetzung zugänglich.

Kältetechnische Komponenten für die Aufstellung in einem Maschinenraum gemäß EN 378-3:2016 + A1:2020, 4.3

Ein Maschinenraum für die Unterbringung aller kältetechnischen Komponenten oder der Hochdruckseite der Anlage muss die Anforderungen der EN 378-3:2016+A1:2020 Punkt 5 erfüllen.

Maschinenräume für Kälteanlagen mit Kältemitteln der Sicherheitsklassen/ Gruppen A2L, A2, A3, B2L, B2, B3 müssen (gem. Punkt 5.14) hinsichtlich ihrer Brennbarkeit beurteilt werden und Gefahrenbereiche entsprechend den Anforderungen des Explosionsschutzes klassifiziert werden.

Die Beurteilung unter Berücksichtigung der Eigenschaften und der Art des Kältemittelaustritts kann ergeben, dass die vom Gefahrenbereich ausgehende Gefahr vernachlässigbar ist.

Unter Berücksichtigung der in EN 378-1:2016+A1:2020, Anhang E für Kältemittel gegebenen praktischen Grenzwerte und der Werte für die Toxizität (ATEL/ODL) und untere Brennbarkeitsgrenze (LFL) sind für die Aufstellung von Kälteanlagen ggf. separate Kältemaschinenräume erforderlich.

Auszug wichtiger Anforderungen an Maschinenräume:

- Im Gefahrenfall muss der Maschinenraum unverzüglich gefahrlos verlassen werden können. Mindestens ein Notausgang muss direkt ins Freie oder in einen Notausgangskorridor führen. Die Türen zu anderen Innenräumen müssen feuerfest (Feuerbeständigkeit von mind. 60 Minuten), dicht, selbstschließend und nach außen zu öffnen sein (Anti-Panik-System, EN 1634-1).
- Wenn es sich nicht um einen separaten Kältemaschinenraum handelt, dürfen die Maschinenräume für kältetechnische Komponenten und auch für die Aufstellung anderer Einrichtungen genutzt werden, sofern die Anforderungen an die Aufstellung mit den Anforderungen an die Sicherheit der Kälteanlage kompatibel sind.
- Ein Kältemittel, das in Maschinenräume entweicht, muss gefahrlos abgeführt werden. Es darf nicht in benachbarte Räume, Treppenhäuser, Höfe, Gänge oder Entwässerungssysteme des Gebäudes gelangen, und entweichendes Gas muss nach außen abgeführt werden.
- Die Luftzufuhr zu Verbrennungsmaschinen, Heizkessel oder Druckluftzeugern muss so ausgeführt sein, dass kein Kältemittel angesaugt wird.
- Kältemaschinenräume müssen mit einer mechanischen Notlüftung ausgerüstet sein. Diese muss von außen und innen, in der Nähe der Tür, schaltbar sein (siehe EN 378-3:2016+A1:2020) Pkt. 5.13.3 (Mechanische Notlüftung).
- Alle Rohrleitungen, Kanäle und Durchführungen, die durch Maschinenräume führen, müssen dicht sein und der Feuerbeständigkeit der Wand entsprechen.
- Die Kälteanlage muss innerhalb und außerhalb des Maschinenraums in der Nähe der Tür abschaltbar sein.